

# COOL BOTTLE RG

Cool Bottle is the perfect grab & go unit for offering cold beverages and packaged products. The integrated product slide ensures that products are replaced automatically to keep the unit looking fully stocked.



## Produkt-Highlights

- Unit uses propane (R290), making it especially environmentally friendly and energy-efficient
- Grab & go: sales display case is open on the customer side for attractive presentation of chilled beverages, food or snacks
- Angled presentation platform ensures perfect overview of all the products offered
- Product slide: sales frontage is always well-stocked as new products slide automatically into place whenever items are taken out to ensure optimised product pressure
- customer side exerp for easy filling
- Perfect for wall placement, as stand-alone solution or combined with other refrigerating and heated display cases
- Quick cleaning: can be cleaned in no time thanks to removable product slide and easily removed plug-in frame

## Temperature range



**Air**  
+5 °C



**Product**  
M2: -1 °C  
to +7 °C



**Room**  
+25 °C and  
60% relative  
humidity



## Accessories and custom options

- RAL powder coating
- Open shelves
- CNS cover

## Dimensions

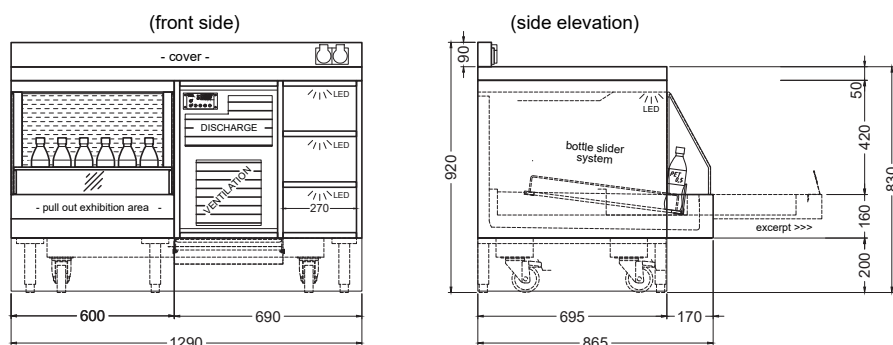

## Technische Daten

Item	Item no.	Dimensions (W x D x H)	Connection	Refrigerant
COOL BOTTLE 60-E RG SONDER	S0412394	600/1290 × 695/865 × 630/920	304 Watt – 230V/50Hz	R290 (propane)