

HOT VARIO 2

This compact and modular heated display case is the perfect take-away solution. Innovative circulating air technology ensures stable temperatures for your packaged hot snacks on 2 levels.



Highlights

- Grab & go: open customer side for easy and quick access
- Stable heat provided by circulating air technology
- Low operating noise thanks to concealed low-noise fan
- Energy-efficient solution with separate regulation of modules depending on demand, time of day and inventory turnover
- Electronic control panel with different features including app control
- Mirror effect visually multiplies the food displayed and visually extends the presentation area
- RAL 9016 matt (Traffic White) powder coating
- Heat-resistant LED lighting with natural colour reproduction

Temperature range



Product
+ 65 °C to
+ 75 °C

Accessories and custom options

- Available with customised RAL colours or uncoated design, CNS polished
- Accessories such as snack waves, snack holders and product slide for perfect presentation and easy removal
- Compatible with the Caleo series or with cooling towers of the same design
- Available as countertop single module, combined or as tower solution

Dimensions

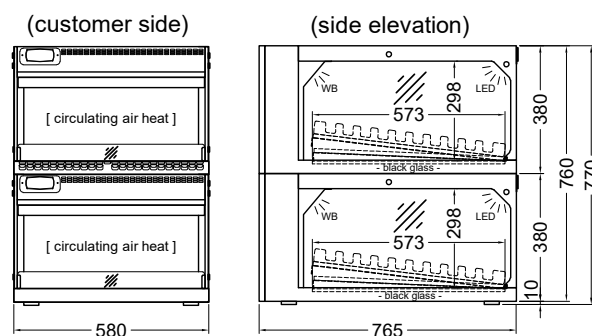

Technical data

Item	Item no.	Dimensions (W x D x H)	Connection
HOT VARIO 2-RAL 9016	S0609046	580 x 765 x 770 mm	1,46 (2 x 0,73) kW – 230V/50Hz