

# DESIGN REFRIGERATED ISLAND

Optimised cooling of foods and appealing product presentation: with its innovative cooling technology and insulated glass frame, the refrigerated island showcases products perfectly, with temperature class M1. The unit is perfectly designed for the sale of all types of packaged products – especially sensitive food such as steaks, grilled meat, fish, cheese, etc.

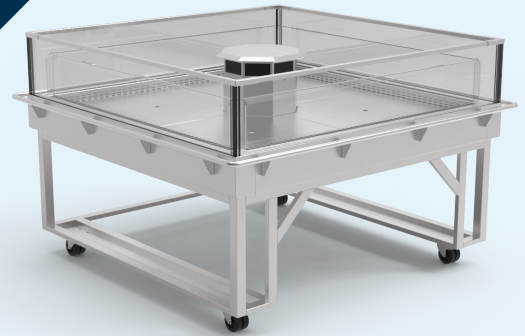

## Highlights

- Eye-catching exclusive design in the centre of the room
- Excellent transparency of products and optimised use of the entire display space
- Temperature range across the entire display area (temperature class M1)
- Complete technology box including rapid locks below the trough for easy maintenance
- Optimised cleaning and perfect hygiene thanks to easy-to-remove elements
- Energy-efficient unit with environmentally friendly refrigerant (propane R290)

### Temperature range



Air  
+2 °C



Product  
3M1 -1 °C  
to +5 °C

## Accessories and custom options

- RAL coating
- Subframe on castors
- Rail around outside edge
- Individual wood cladding possible due to drawer design



## Dimensions

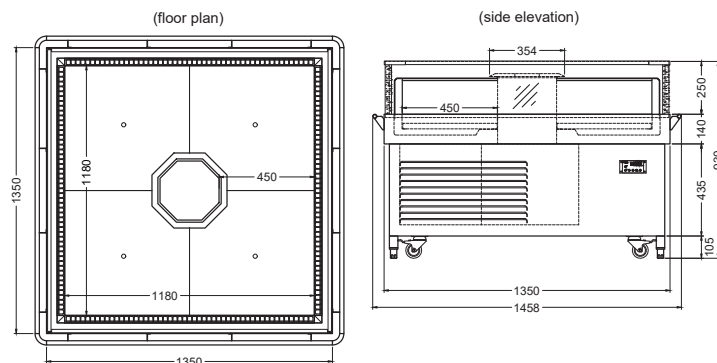

Item	Item no.	Dimensions (W x D x H)	Connection	Voltage	Refrigerant
KÜHLINSEL UKW E 135-E R290	EU358650	1350 x 1350 x 930 mm	310 Watt	230V 50Hz	R290 (propane)