

PACKAGING STATION

Efficient packaging of goods: everything is within easy reach, clean and hygienic, and systematically structured - the Packaging Station from IDEAL AKE.



Highlights

- Optional non-refrigerated drawers, doors or compartments in the base
- Shelf area for bulk goods, packaging material, etc.
- Plug sockets either on top in the shelf area or on the rear wall
- Doors with 180° opening angles and drawers with fully extendable runners for optimal handling
- Rounded drawer baskets, side-welded handle strips
- Designed for easy servicing and maintenance, e.g. no tools required to replace the door and drawer seals, drawer runners with plug-in system
- Stable door and drawer fronts are pleasant to the touch,
- high-quality CNS used. Optionally also available in V4A material quality

Dimensions

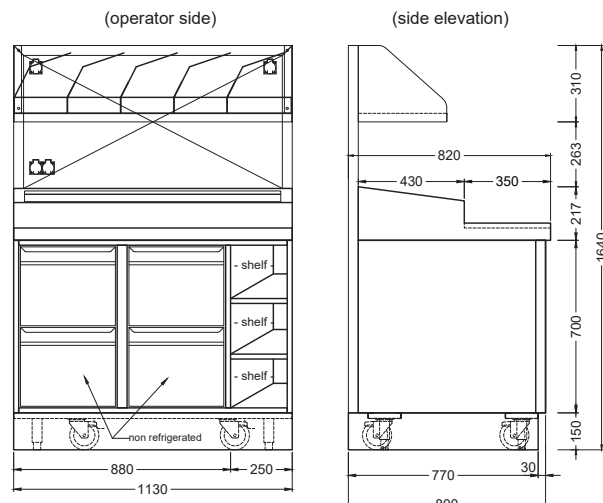

Technical data

Item	Item no.	Dimensions (W x D x H)
2 x S2-44-70 + OSB 25-70	80091281	1130 x 820 x 1640 mm